

Softmaster⁷ ROE 2

Microprocessor controllers for reverse osmosis plants

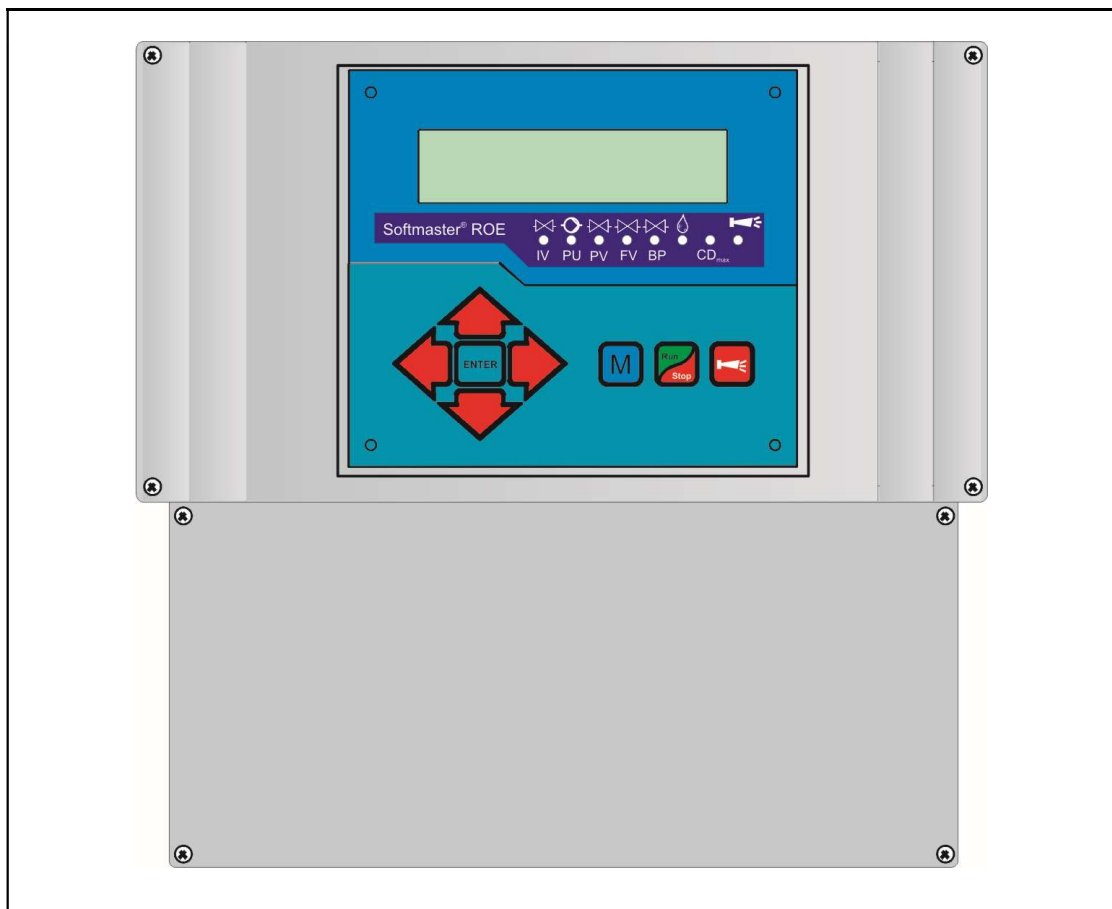

Operating instructions

Table of contents

Table of contents	2	End menu	22
General notes	3	Information menu.....	22
Introduction	3	Programming	22
Handling notes	3	Enter password.....	22
Safety notes	3	Change password.....	22
Installation and commissioning	3	Flushing mode	22
General description	4	Flushing duration	23
Views of unit.....	4	Interval flush	23
Description of display and operating features.....	5	Quality flush.....	23
Display functions.....	6	Probe CD1 Permeate	23
LED displays	6	LV Permeate Max.,.....	23
Operating displays	7	LV Permeate Min.,.....	23
Error messages	7	Temperature compensation	24
Terminal block identification	11	LV Temperature.....	24
Functions (IN = input, OUT = output).....	11	Function Pump	24
Description of relay outputs	13	Function Low water pressure	24
PU1 / PU2, pressure pumps 1 and 2	13	Function Excess pressure	25
IV Input valve	13	Function Concentrate	25
FV Flush valve.....	13	Function Motor protection.....	25
PV Output valve (Permeate valve)	13	Function Stop	25
BP By-pass valve (emergency program).....	14	Function PROG	25
PR programmable function output	14	Water meter	26
AL Fault message output ("Alarm").....	14	Metering.....	26
Description of signal inputs	15	Funct. IN 0/4-20mA input	26
MP Motor protection	15	Function OUT PR output	26
HL and LL High and Low level.....	15	Interface.....	26
HP Excess pressure	16	Baud rate	26
LP Low water pressure	16	Release	27
STOP Switch off of the plant.....	17	Language.....	27
CO Concentrate monitoring	17	Serial number	27
PROG Programmable function input	17	ASERVICE@ menu	27
CD1 Connection for conductivity sensor.....	18	Operating hours.....	29
PT100 Connection for temperature sensor PT100	19	Water meter	29
OUT Interface	19	Pressure	29
Functioning	20	Time/Date	29
Switching on and power failure.....	20	Diagnosis.....	29
Production / Run	20	Software status.....	29
Standby	20	Menu structure	30
Flush after production	20	Technical appendix	31
Interval flush	20	Example for an osmosis plant layout.....	31
Quality flush and emergency service	20	Connection example.....	32
Emergency program / By-pass	21	Connection example for 24 V	33
Conductivity monitoring	21	Conformity Declaration	34
Programming	22	Technical Data.....	35
Start menu.....	22		
Menu selection	22		
Input	22		

General notes

Introduction

These operating instructions describe the installation, operation and programming of the reverse osmosis controller Softmaster ROE 2.

We recommend that, whilst familiarising yourself with the operation of the unit aided by this manual, you have immediate access to the operable controller in order to perform the functions and combinations as described. As certain functions are interrelated, it is advisable to follow the instructions in the given order.

Should problems or questions arise which are not described in this manual and/or cannot be solved, our customer service is always at your disposal.

Try to identify the problem as accurately as possible and record the conditions under which it occurred. This will enable us to offer you swift effective assistance.

Handling notes

Quick, repeated switching on/off of the controller should be avoided. Wait at least 5 seconds before switching the unit either 'on' or 'off' at the main switch.

Only operate the controller in compliance with the ambient conditions (e.g. temperature, moisture) stated in the chapter entitled technical data. Especially protect the controller against moisture.

The controller should not come into contact with splash or condensation water.

Before dismantling a defect controller, always write down the description of the error (failure effect). Repair work (independent of the guarantee period) is only possible after the unit has been dismantled and returned to us with a description of the error.

The warranty shall not apply if the controller is tampered with, altered, modified or repaired contrary to the instructions described in this manual.

The allowed maximum electrical load capacity of the relay outputs and the total power rating of the plant must not be exceeded.

The controller should only be used for the stated intended purpose.

Safety notes

Always pay attention to the following safety notes:

Only connect the device to the mains voltage displayed on the type plate. The controller must be installed and operated in compliance with the relevant standards (e.g. DIN, VDE, UVV), or in accordance with the regulations laid down by the individual country.

Some functions (e.g. manual production) allow direct manipulation of the plant (valves, pumps, etc.), without locking or monitoring. These functions are thus protected by a password and are only to be used by trained personnel.

If you observe malfunctioning of the controller, switch it off immediately and inform the service personnel.

Do not attempt to repair the controller yourself (loss of warranty rights); instead always get in touch with authorized service personnel. This is the only way a reliable and safe operation of the plant can be ensured.

After protective equipment (safety fuse, motor protection circuit breaker) has been triggered, attempt, at first, to eliminate the cause of the malfunctioning (e.g. clean the pump) before reactivating the protective equipment. Frequent triggering is always due to an error which, in certain circumstances, may also cause damage to the controller.

Ignoring these notes can result in damage to the controller as well as the plant and may result in a loss of warranty rights.

Installation and commissioning

Installation as well as commissioning must only be undertaken by authorized technicians!

The connecting cables to the sensors should be kept as short as possible and **clear** of power cables. Close proximity to strong electromagnetic radiators can lead to deviations of the display; in this case, separate interference suppression measures should be carried out.

After installation, program the unit with the plant-specific features and data (e.g. switch functions, conductivity limit values, etc.). The data is permanently stored (also during power failure).

General description

Views of unit

Wall-mounted variant

.....

Panel-mounted variant

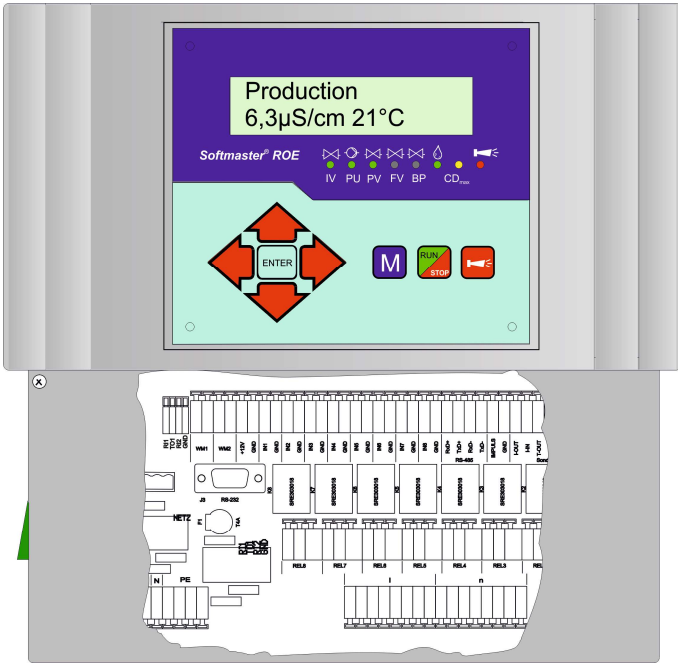

Terminal box

.....

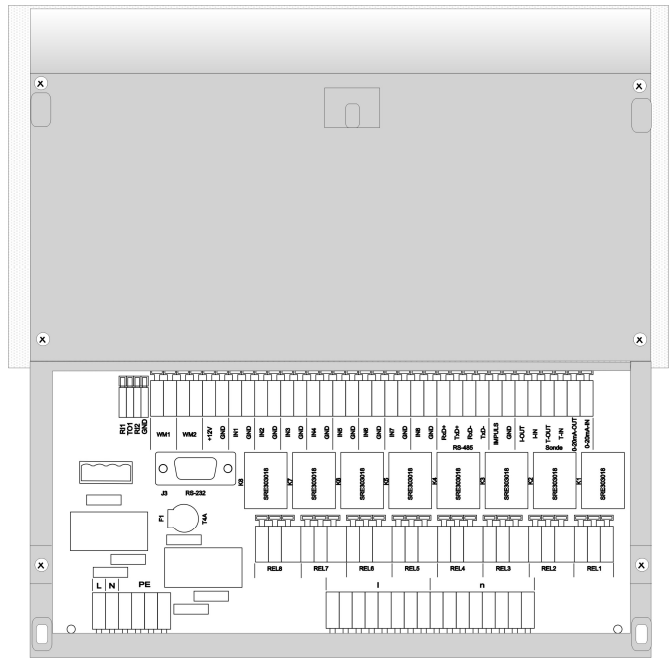

Terminal box

Drilling scheme for wall-mounted variant

Panel cut-out for panel-mounted variant

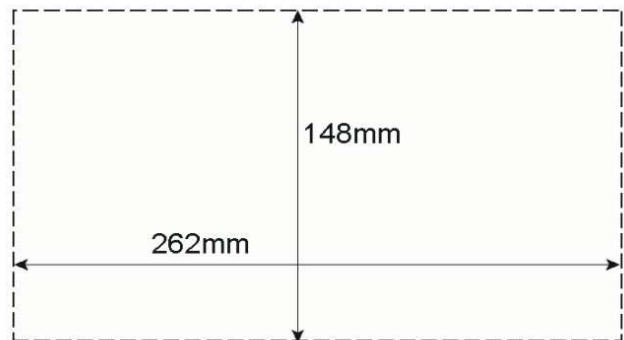
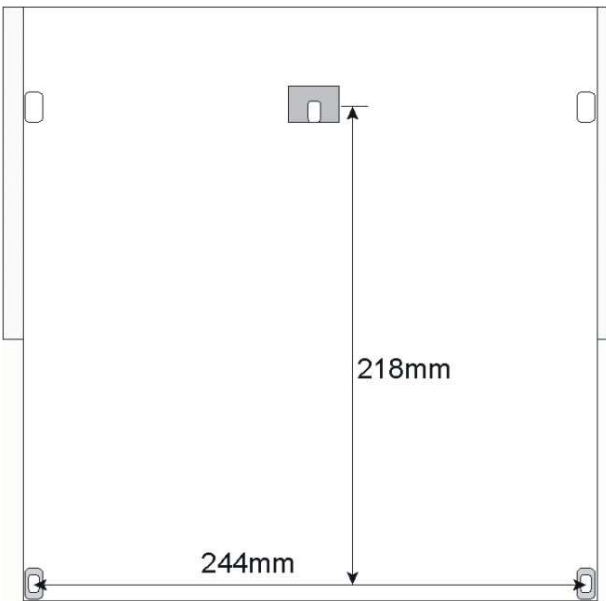

Description of display and operating features

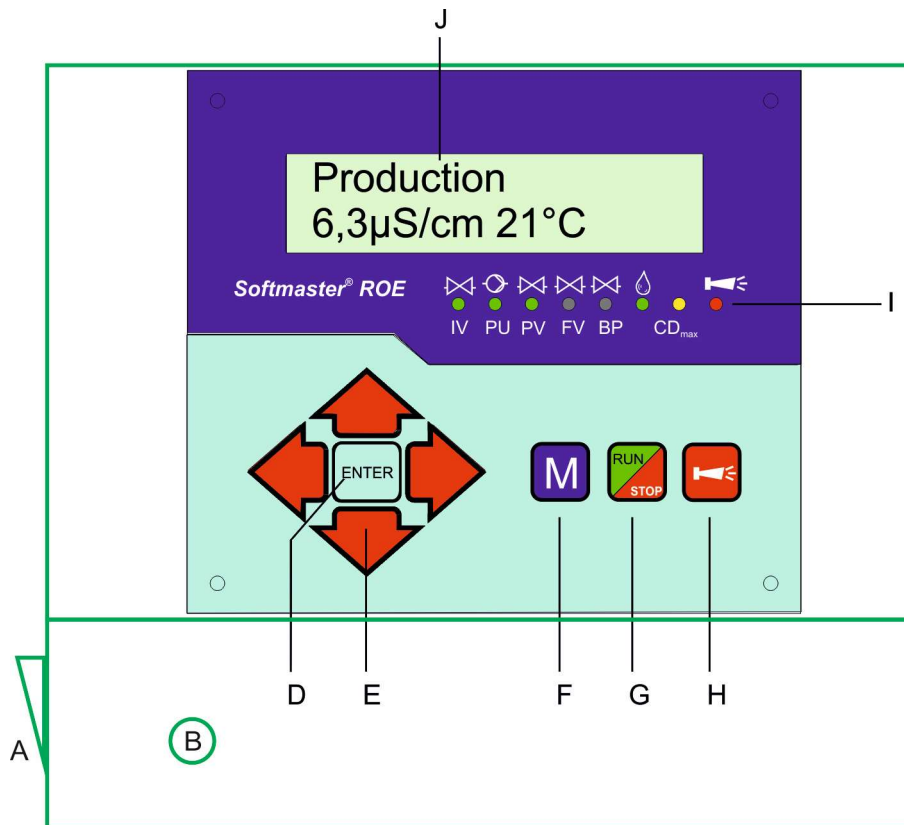

A On/Off switch

Only the wall-mounted variant is equipped with a On/Off switch. Use this switch to switch the unit on or off.

B Safety fuse, max. T6.3A

The safety fuse protects the outputs against overload or a short circuit. (Inside the unit)

C Thermal fuse (optional)

Thermal fuse protection for the pump motor, max. 6.3 A.

D "ENTER" key

Confirm inputs and trigger functions with the ENTER key.

E Arrow keys

Use these keys to operate the menu drive in the display and to enter values and programming data.

F "M" key

Call the menu and return from submenu levels.

G "Run/Stop" key (AProduction/Standby@)

Manual triggering of production: Plant is put into operation or manual triggering for STOP/ Standby: Plant goes into the Standby position.

H "Fault OFF" key

Deletes the alarm signal at output 'AL' (Alarm); a fault display can only be deleted if the fault has been eliminated.

I LED functions

LED symbols always signal the status of the plant, independent of the level (menu) being worked on.

J LC display

Two lines, each line with 16 characters, backlit.

Display functions

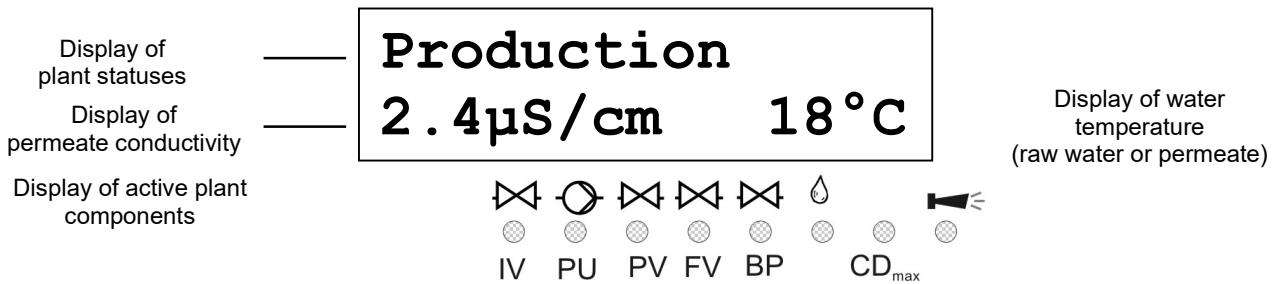

Display - top line

The top line displays plant statuses and error messages (described below).

Display - bottom line

The bottom line displays the conductivity (see technical data for measuring ranges) and water temperature (2-digit, only with automatic temperature compensation).

LED displays

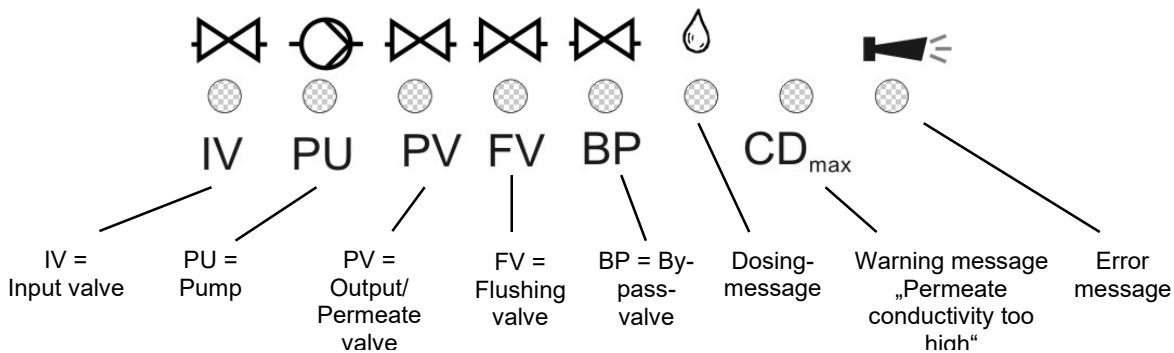

The LEDs display active plant components and occurring error messages.

IV (green)

LED lights up: Input valve is open.

PU (green)

LED lights up: Pump 1 and/or pump 2 is/are switched on.

PV (green)

LED lights up: Output/Permeate valve is open.

FV (green)

LED lights up: Flush valve is open.

BP (green)

LED lights up: By-pass valve is open.

Metering message (green)

LED lights up as long as the impulse output is activated.

Warning message AConductivity too high@ (yellow)

LED lights up: The limit value CD_{max} has been exceeded.

Error message AAlarm@ (red)

LED lights up: Alarm relay activated, error message not confirmed yet and error still occurring.

LED flashes: Alarm relay no longer active, error message has been confirmed but the error is still occurring. As long as an error is still occurring, it is shown alternately with the operating display.

Operating displays

Production 12.3µS/cm 21°C	Plant is in operation and produces permeate with 12.3µS/cm of conductivity at a water temperature of 21°C.
Standby 243µS/cm	Plant is on Standby with a permeate conductivity of 243 µS/cm.
Flush 10m	Flush program is active (flush after production or interval flush), Residual time 10 minutes.
Quality Flush 197.3µS/cm	Quality flush during production is active with a permeate conductivity of 197.3µS/cm.

The LED ACDmax@ lights up additionally.
Program the duration of the quality flush in the BASIC PROGRAM menu.

Stop	Plant has been stopped via the STOP input and is locked. It is only possible to restart production with the ARun/Stop@ key after the stop input has been released.
------	--

Error messages

**In addition to the displayed error messages, the red LED AAlarm@ lights up or flashes.
Alternate display of all error messages and operating displays.
Each occurred error is stored in the error history.**

Error message APower failure@

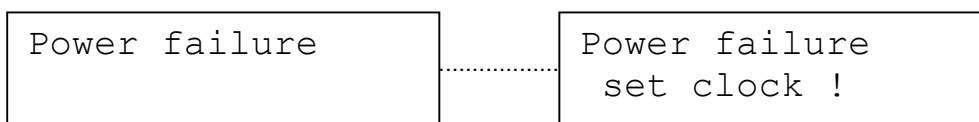

Message after each switching on: @power failure@. Acknowledge the fault display via the @Alarm@ key. Check the time and, if necessary, set the time. After this, the unit is without a real-time clock (plug-in card RTC/RS232).

After switching on or after voltage recovery, the controller starts with @STANDBY@.

Check the plant for possible negative results due to the power failure.

All stored values remain stored even during power failure. The real-time clock is battery buffered and thus keeps on running.

Error message ACD Permeate Max@

CD Permeate Max
64.4µS/cm

Permeate conductivity is bigger than the set limit value ALV Permeate Max@

The maximum permeate conductivity has been exceeded for a longer period than the programmed test time (Delay Max) during. The error message is displayed and, according to the programming, the plant has been switched off.

In addition to the error message, the yellow warning light @CDmax@ lights up.

Confirm the fault display via the @Alarm@ key.

Check the plant settings and raw water quality or check the units for possible defects.

The error display is only deleted after the fault has been eliminated

Error message ACD Permeate Min@

CD Permeate Min
1.2µS/cm

Permeate conductivity is smaller than the set limit value ALV Permeate Min@.

The minimum permeate conductivity has fallen below the limit value for a longer period than the programmed test time (Delay Min) during production. The error message is displayed and, according to the programming, the plant has been switched off.

Confirm the fault display with the AAlarm@ key.

Check the conductivity sensor and its supply lines for interruption. There might be air in the permeate line and the sensor is not washed by water.

The error display is only deleted after the fault has been eliminated.

Error message ATemperature Max@

Temperature Max
16.8µS/cm 43°C

The water temperature is higher than the set limit value ALV Temperature@

The maximum water temperature has been exceeded for a longer period than the programmed test time (Delay) during production.

Confirm the fault display with the AAlarm@ key.

The error display is only deleted after the fault has been eliminated.

Error message ALow water pressureA

Low water
pressure

The pressure switch in front of the pressure pump for the dry-running protection has triggered.

The plant has been switched off after the programmed delay time (Delay LP). Restart the plant with the "RUN/STOP" key. If water is still low, the plant is switched off again after the delay time.

When automatically controlling the re-filling of the storage tank, the plant is restarted 10 minutes after it has been switched off via the dry-running switch.

Program the number of restart attempts after low water pressure under ASwitch on@ in menu AFunct. low water pressure@.

Confirm the fault display with the AAlarm@ key.

The error display is only deleted after the fault has been eliminated.

Error message AExcess pressure@

Excess pressure 16.8µS/cm 18°C

The pressure switch behind the pressure pump for the protection of the units against excess pressure has triggered.

The plant has been switched off after the programmed delay time (Delay HP). Restart the plant via the "RUN/STOP" key. If renewed excess pressure occurs, the plant is switched off again after the delay time.

Confirm the fault display with the AAlarm@ key.

The error display is only deleted after the fault has been eliminated.

Error message AMotor protection@

Motor protection 16.8µS/cm 18°C

The motor protection circuit breaker of the pressure pump has triggered.

After triggering the protective switch, the plant has been switched off immediately. Restart the plant via the "RUN/STOP" key if the motor protection has been re-released.

Confirm the fault display with the AAlarm@ key.

The error display is only deleted after the fault has been eliminated.

Error message AConcentrate flow@

Concentrate flow 16.8µS/cm 18°C

The flow controller in the concentrate line has triggered because the concentrate quantity is too low.

The error message is displayed and, according to the programming, the plant has been switched off after the programmed delay time (Delay CO). Restart the plant with the "RUN/STOP" key.

Confirm the fault display with the AAlarm@ key.

The error display is only deleted after the fault has been eliminated.

Error message AConductivity measuring range has been exceeded@

Exceed range CD OFL µS/cm 18°C

The measuring range of the conductivity measuring instrument has been exceeded.

Confirm the fault display with the AAlarm@ key.

Check whether short circuiting has occurred in the sensor or its supply lines and also check the programming of the cell constants.

Confirm the fault display with the AAlarm@ key.

The error display is only deleted after the fault has been eliminated.

Error message ATank overflow@

Tank overflow 16.8µS/cm 18°C

The storage tank is overflowing.
The tank overflow signal occurs at contact input PROG and the input is programmed as ATank overflow@ contact.

Confirm the fault display with the AAlarm@ key.

Check the storage tank and its tank overflow line as well as the AFULL@ contact of the level controller.

The error display is only deleted after the fault has been eliminated.

Error message AExcess quality flushing duration has been exceeded@

Exc.Q-flush. time
196.2µS/cm 18°C

Even after quality flush, the permeate conductivity is still bigger than the set limit value ALV Permeate Max@.

The error message is displayed and emergency service starts.

The yellow warning light **ACDmax@** additionally lights up.

Confirm the fault display with the **AAAlarm@** key.

Check the settings of the plant and the raw water quality or check the units for possible defects.

The error display is only deleted after the fault has been eliminated.

Error message ATemperature low@

Temperature low
16.8µS/cm 0°C

The water temperature is lower than 0.5°C.

The water temperature during production has fallen below the minimum water temperature.

Check whether short circuiting has occurred in the sensor or the temperature sensor PT100 or in their supply lines.

Confirm the fault display with the **AAAlarm@** key.

The error display is only deleted after the fault has been eliminated.

Error message AEmergency program / By-pass@

Emerg.program /BP
16.8µS/cm 18°C

The level in the storage tank is below Empty-level.

The signal occurs at contact input PROG and the input is programmed as AEmergency program BP@ contact.

Confirm the fault display with the **AAAlarm@** key.

Check the plant and, if necessary, its design as well as the AEMPTYA contact of the level controller. It is possible that it is not sufficiently supplied if the production from the storage tank is too high.

The error display is only deleted after the fault has been eliminated.

Terminal block identification

Functions (IN = input, OUT = output)

No.	Terminal	Type	Function	Note
	PE	IN	4x Mains-Protective earth	
	N L	IN	Mains, N = Neutral Mains, L = Live	Mains-input 230 - 240 V AC
	n l	OUT	8x Neutral switched 8x Live switched	Mains voltage, max. 4 A
1 2 3	PU1	OUT	Pump 1 - normally open Pump 1 - common Pump 1 - normally closed	Mains voltage, max. 6 A
4 5 6	PU2	OUT	Pump 2 - normally open Pump 2 - common Pump 2 - normally closed	Mains voltage, max. 6 A
7 8 9	IV	OUT	Input valve - normally open Input valve - common Input valve - normally closed	Mains voltage, max. 4 A
10 11 12	PV	OUT	Output valve - normally open Output valve - common Output valve - normally closed	Mains voltage, max. 4 A
13 14 15	FV	OUT	Flush valve - normally open Flush valve - common Flush valve - normally closed	Mains voltage, max. 4 A
16 17 18	BP	OUT	By-pass valve - normally open By-pass valve - common By-pass valve - normally closed	Mains voltage, max. 4 A
19 20 21	PR	OUT	programmable message output ATank empty@, ACdmax@, AStop@ (see "Programming")	Volt-free relay output max. load 240 V AC, 4 A
22 23 24	AL	OUT	Fault message output - normally open Fault message output - common Fault message output - normally closed	Volt-free relay output max. load 240 V AC, 4 A
25 26	WM1 ⊥	IN	Water meter input 1 common load for inputs	See water meter description!
27 28	WM2 ⊥	IN	Water meter input 2 common load for inputs	See water meter description!
29 30	+12V ⊥	IN	12V-supply for turbine common load for inputs	See water meter description!
31 32	HP ⊥	IN	Overpressure message common load for inputs	Only for volt-free normally open/ normally closed contact!
33 34	LP ⊥	IN	Low water message common load for inputs	Only for volt-free normally open/ normally closed contact!
35 36	CO ⊥	IN	Concentrate monitoring common load for inputs	Only for volt-free normally open/ normally closed contact!
37 38	HL ⊥	IN	Storage tank FULL common load for inputs	Only for volt-free normally open/ normally closed contact!
39 40	LL ⊥	IN	Storage tank EMPTY common load for inputs	Only for volt-free normally open/ normally closed contact!
41 42	MP ⊥	IN	external motor protection circuit breaker common load for inputs	Only for volt-free normally open/ normally closed contact!
43 44	STOP ⊥	IN	Stop plant common load for inputs	Only for volt-free normally open/ normally closed contact!
45 46	PROG ⊥	IN	Emergency service (By-pass), see "Programming@ common load for inputs	Only for volt-free normally open/ normally closed contact!
47 48 49 50	RxD+ I-OUT- / TxD+ RxD- I-OUT+ / TxD-	OUT/ IN	Current interface 0/4-20mA (standard) Serial interface RS485 (optional)	- indirect-coupled - RS485, not indirect-coupled
51 52	Impulse	OUT	Metering impulse (open collector) Emitter	Max. load 50mA / 30V, see metering output description
53 54	CD1	IN	Conductivity electrode for permeate	
55 56	PT100	IN	Temperature sensor PT100	Water temperature (permeate or raw water)
57 58	⊥ IN 4-20mA	IN	common load Signal of pressure sensor	4-20mA-input, see pressure input description

Continuation of terminal block identification

No.	Terminal	Type	Function	Note
	RI1 TO1 RI2 GND	IN/ OUT	Serial interface RS232, RxD Serial interface RS232, TxD Serial interface RS232, DTR/DSR Serial interface RS232, load	Parallel to D-SUB-plug RS-232 (J3)

Terminal blocks for mains supply and relay outputs (displayed relay position: Device reenergised)

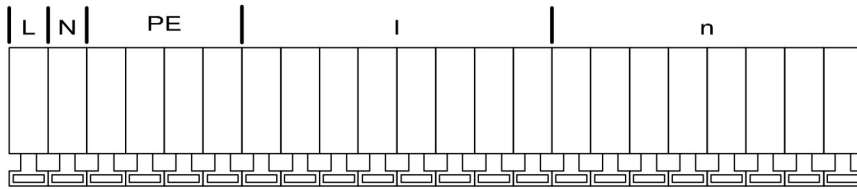
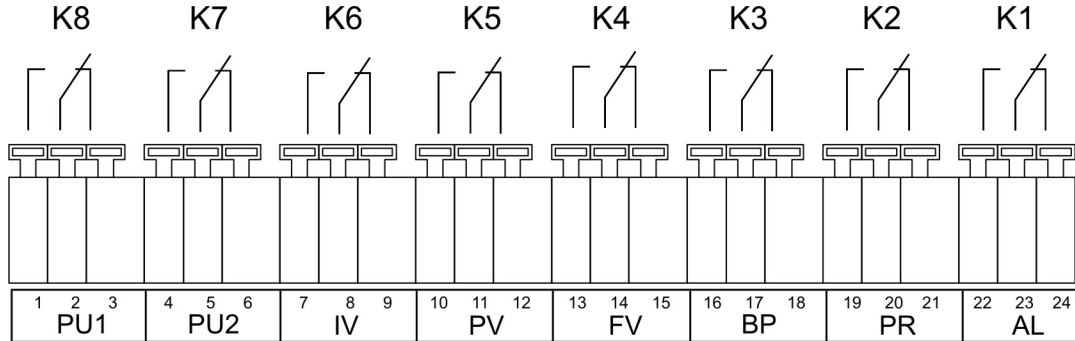

Terminal block for inputs and interface

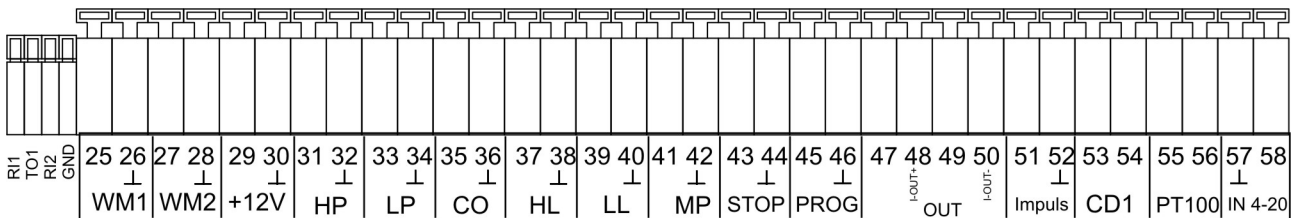

Serial interface RS232

- PIN 2 - RxD
- PIN 3 - TxD
- PIN 4 - DSR, DTR
- PIN 5 - GND, load

Please observe that the peripheral devices are connected via a neutral modem cable!

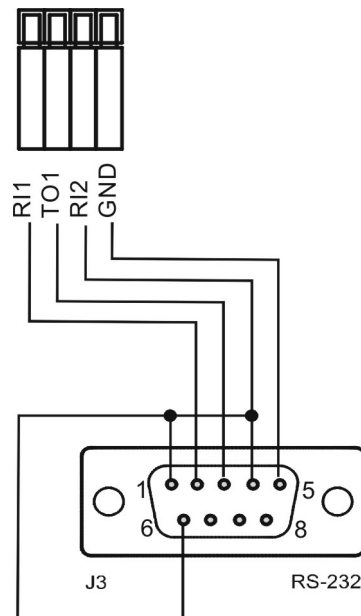

Description of relay outputs

PU1 / PU2, pressure pumps 1 and 2

Driving motors with different power consumptions can be used for the pressure pump of the osmosis plant. Fuse protection occurs internally via a safety fuse T6.3A. When using a three-phase motor, an appropriate power protection contactor has to be pre-connected.

The input valve always opens when switching to production. The pressure pump starts after a programmable delay time. Four operating modes can be selected:

- Production only with pump 1,
 - Production only with pump 2,
 - Serial connection = Pump 1 and pump 2 are connected in series. Output PU2 is switched with a delay after PU1 has been switched on.
 - Change-over connection: The pumps are installed in parallel and are operated alternately.
- Set the operating mode and test time under menu option

"M" ≡ BASIC PROGRAM ≡ Fct. Pump

If the pump is equipped with a motor protection circuit breaker with a volt-free message contact, it is possible to connect it to input "MP". The controller will then monitor pump faults (see description of input MP motor protection).

Cycle diagram pump delay:

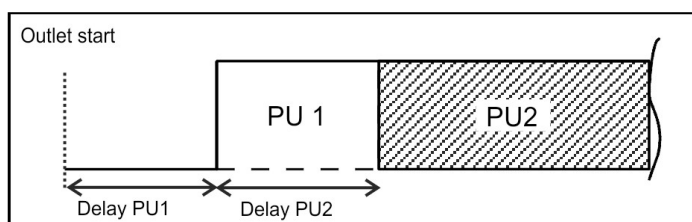

IV Input valve

The input valve is open during "ProductionA, AQuality flush@ and AFlush". It should be designed in a way that it opens under control voltage. Use the following menu option to program that the input valve is closed during flush:

"M" ≡ BASIC PROGRAM ≡ FLUSHING MODE ≡ with valve IV

FV Flush valve

The osmosis plant can be equipped with a flush valve in order to avoid unacceptable high deposits at the units. Flush can take place after the end of the "Production" and/or in fixed intervals after the last switching to the "Standby" position. Interval flush prevents unacceptable bacterial contamination of the units.

Flush is interrupted as soon as the controller switches to "Production", e.g. when pressing the "Production" key or if water is requested via a level transmitter in the storage tank.

No interval flush occurs after production stop.

Program the flushing duration (0 - 99 minutes), flushing mode (with/without pump or with pump 1 + 2) and the interval flush in the basic program.

"M" ≡ BASIC PROGRAM ≡ FLUSHING DURATION or FLUSHING MODE or INTERVAL FLUSH.

PV Output valve (Permeate valve)

This valve is open as long as the water conductivity is below the set limit value "LV Permeate Max". A flush valve which closes under voltage can be connected instead of the output valve. The use of both valves or of a 3/2-way valve is also possible. Use the following menu option to program whether the output valve should be closed or not during flush:

"M" ≡ BASIC PROGRAM ≡ FLUSHING MODE ≡ with valve PV

BP By-pass valve (emergency program)

A level transmitter which is installed below the empty level of the storage tank is required for the operation of the plant with emergency program. Connect the switch to the input "PROG". Output "BP" switches if the level "Emergency program" is insufficient.

"M" ≡ BASIC PROGRAM ≡ Funct. PROG ≡ Em.program/BP

PR programmable function output

It is possible to program the function of this volt-free relay output as follows:

1. **CDmax:** Relay switches if the conductivity @CDmax.@ has been exceeded and/or
2. **Tank empty:** Relay switches if the storage tank is empty and/or
3. **Production:** Relay switches if the plant is in operation and/or
4. **Stop/Standby:** Relay switches if the plant is in Standby or has been stopped

"M" ≡ BASIC PROGRAM ≡ Funct. OUT PR

AL Fault message output ("Alarm")

Output "AL" is a volt-free change-over relay contact. During trouble-free operation, the contact between the terminals 22 - 23 is closed and the one between terminals 23 - 24 is open. During power failure or if an error occurs, the contact between terminals 23 - 24 is closed and the one between 22 - 23 is open.

The controller monitors several plant statuses. Output "AL" remains activated (terminals 22 - 23 closed) until the fault ceases.

A fault is displayed with the red LED "Error message" and on the display.

The fault message signal at output "AL" is deleted by confirming the fault with the "Alarm" key.

The fault display can only be deleted if the fault has been eliminated.

The following faults activate output "AL" and are displayed if the osmosis plant has been equipped with the appropriate sensors:

Statuses which **always** trigger a fault message:

Power failure
Motor protection MP
Low water pressure LP (after switch off)
Concentrate low CO
Excess pressure HP
Max. q. flushing duration exceeded
Min. conductivity exceeded
Max. conductivity exceeded
Cond. measuring range exceeded

Max. water temperature exceeded
Min. water temperature insufficient
Max. pressure exceeded

According to the programmed PROG input:

Emergency program (By-pass) active
Tank overflow

See the section entitled @Programming@ for further descriptions about error messages.

Impulse / Metering output

Use the output "Impulse" to control a dosing pump if an anti-scaling medium is to be dosed during production or flush. For this, a water meter has to be connected to input "WM1" or "WM2". The impulse ratio is adjustable.

Example:

An impulse length of 1 second should be given per 50 litres:

L/Imp. = 50, l.length = 1sec

"M" ≡ BASIC PROGRAM ≡ Metering

"M" ≡ BASIC PROGRAM ≡ Water meter 1

"M" ≡ BASIC PROGRAM ≡ Water meter 2

The output is an open collector transistor with a **max. load capacity of 50mA / 30V**.

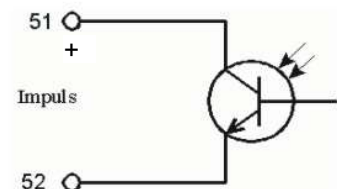

Description of signal inputs

Note!

Connect the signal inputs "MP", "HL", "LL", "HP", "LP", "STOP", "CO" and "PROG" only to **volt-free** contacts!

MP Motor protection

When using pumps which are equipped with a motor protection circuit breaker with a volt-free message contact, it is possible to connect this switch to input "MP". The controller will then monitor and, according to the programming, evaluate pump faults.

Type of connection in plant concepts with two pumps:

Function	Test time	Type of contact	Type of contact connection	Action
S Message contact of an external motor protection circuit breaker	2 seconds	Normally closed	Serial connection	S Switch off
		Normally open	Parallel connection	S Continuous alarm S Entry in error list

Please program the input "MP" according to the operating mode of the message contact:

"M" ≡ BASIC PROGRAM ≡ Funct. Motor prot.

HL and LL High and Low level

Connections for volt-free contacts

Function	Test time	Type of contact	Action
HL S Level transmitter input "Full Level" S Pressure switch input	seconds	Normally closed 2	S End production (with a connected High level transmitter) S Start production (with a connected pressure switch)
LL S Level transmitter input "Low Level"	seconds	Normally open 2	S Start production (with a connected Low level transmitter)

The connections "HL" and "LL" can be used for controlling the production:

a) For plants with a storage tank:

As soon as the lower level "Tank empty" (connection "LL") has been reached, the contact transmitter closes and the plant is switched on ("Production"). It is only switched off again if the upper level "Tank full" (connection "HL") has been reached and this contact transmitter opens.

It is also possible to use only an upper level transmitter (float switch) or a remote control switch (Production/Standby) instead of two level transmitters. In this case, the connection "LL" has to be connected via a bridge with "⊥". The ARun / Stop@ key ("Production / Standby") will then be without function.

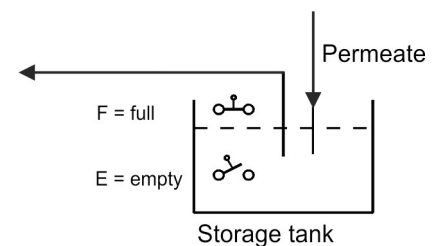

Note!

If using automatic concentrate displacement via permeate (flush), observe that, depending on the pressure ratios, soft water can still run into the storage tank until the end of the flushing duration. Due to this, the upper level transmitter has to be arranged in a way that a tank overflow is avoided. For safety reasons, the tank should in any case have a tank overflow.

Connect this switch to the programmable signal input "PROG". The plant automatically switches off if the "Tank overflow level" has been reached.

Note!

When operating the osmosis plant without a level transmitter (manual operation), a bridge has to be connected across the connection AHLA. A bridging of the connection "LL" is **not** allowed.

b) For plants with one pressure switch or remote control switch:

Connect a bridge to the connection "LL" and the pressure switch to the connection "HL". The pressure switch must have a normally closed contact.

HP Excess pressure

Connection for volt-free pressure switch

Function	Type of contact	Test time	Action
Pressure monitoring in front of or behind the unit	programmable normally closed/ normally open	programmable 01 - 99 seconds	S Switch off of the plant S Continuous alarm S Entry in error list

Install a maximum pressure governor either at the raw water side or at the concentrate side in order to protect the unit. A serial or parallel connection of two maximum pressure governors is also possible.

If the pressure governor switches, the plant is switched off after a programmable test time. The fault is displayed with the red LED "Error message" and on the display. A continuous alarm occurs at output "Alarm" and an entry in the error list takes place.

"M" ≡ BASIC PROGRAM ≡ Funct. Excess pressure

Press the "Production" key to restart the plant. If the pressure is still too high, the plant is once again switched off after the test time.

Note!

When operating the osmosis plant without maximum pressure governor, the connection "HP" has to be bridged and programmed as normally open.

LP Low water pressure

Connection for volt-free pressure switch

Function	Type of contact	Test time	Action
Pressure monitoring in front of the pump	programmable normally closed/ normally open	programmable 01 - 99 seconds	programmable S Restart, up to 9 x not programmable S Switch off of the plant S Continuous alarm after switch off S Entry in error list

Install a pressure switch in front of the pump in order to protect the pressure pump. A serial or parallel connection of two pressure switches is also possible.

If the pressure switch switches, the plant is switched off after a programmable test time. The fault is displayed with the red LED "Error message" and on the display. A continuous alarm occurs at output "Alarm" and an entry in the error list takes place (if the number of restarts has been reached).

"M" ≡ BASIC PROGRAM ≡ Funct. Low water

Only for controller operation with level transmitter: It is possible to program the reaction of the controller during low water. Determine how often the plant is to be restarted.

Restart occurs after 10 minutes (fixed). If the water is still too low, the plant is once again switched off after the test time and until the number of restarts has been reached.

Note!

When operating the osmosis plant without a pressure governor for low water identification, the connection "LP" has to be bridged or programmed as normally open.

STOP Switch off of the plant

Connection for volt-free pressure contact

Function	Type of contact	Test time	Action
External switch off of the plant	programmable normally closed/ normally open	programmable 01 - 99 seconds	S switch off of the plant

During a production, it might be necessary to interrupt the production externally via a switch. In the case of pre-connected single filter plants, the osmosis plant should not switch to AProductionA during regeneration in order to avoid the operation of units with hard water.

The plant switches off if the input is activated (as normally closed or normally open).

The start of production and the interval flush is suppressed via the function "STOP".

"M" ≡ BASIC PROGRAM ≡ Funct. Stop

CO Concentrate monitoring

Connection for volt-free contact

Function	Type of contact	Test time	Action
Concentrate flow monitoring	programmable normally closed/normally open	programmable 01 - 99 seconds	S Continuous alarm S Entry in error list programmable: S Switch off of the plant

In order to protect the unit, it is possible to monitor the concentrate flow with a flow meter equipped with a limit contact maker. The plant can be switched off after a programmable test time if the limit contact maker switches. The fault is displayed with the red LED "Error message" and on the display. A continuous alarm or a message impulse occurs at output "Alarm" and an entry in the error list takes place.

"M" ≡ BASIC PROGRAM ≡ Funct. Concentrate

Note!

When operating the osmosis plant without concentrate monitoring, the connection "CO" has to be bridged or programmed as normally open.

PROG Programmable function input

Connection for volt-free contact

Function	Type of contact	Test time	Action
programmed as level transmitter input "Em. program/ BP"	programmable normally closed/normally open	none	S By-pass valve opens S Continuous alarm S Entry in error list
programmed as level transmitter input "Tank overflow"	programmable normally closed/normally open	none	S Production Stop, Flush stop S Continuous alarm S Entry in error list

"M" ≡ BASIC PROGRAM ≡ Funct. PROG

It is possible to use the input "PROG" to connect a level transmitter (monitoring of the storage tank) for extended plant monitoring:

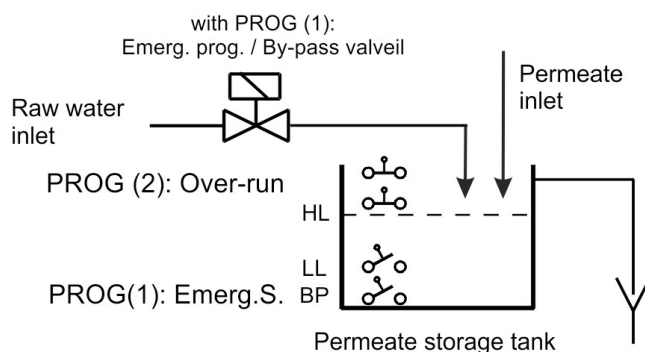

CD1 Connection for conductivity sensor

Equip the unit with a measuring amplifier for conductivity measurement.

The conductivity sensor at connection CD1 measures and monitors the permeate conductivity.

Different measuring ranges arise due to the connection of sensors with different cell constants: see chapter ATechnical data@.

Terminal block identification:

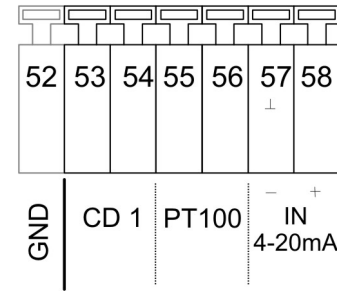

If the measuring range is exceeded, "OFL" appears in the conductivity display and the error message AExceed range CD@ is additionally displayed.

Program the used cell constant of the permeate monitoring under:

"M" ≡ BASIC PROGRAM ≡ Sensor Permeate

It is possible to use deviating cell constants by calibrating the sensor with a conductivity calibration solvent. Use AdryA or zero point calibration to balance measured value distortions due to cable capacities. For this, please observe the description about calibration.

See the function description Aconductivity monitoringA for information about the functionality of the limit values.

IN 4-20mA, Input for pressure sensor

The pump pressure before the unit/s is measured with a pressure transmitter at connection AIN 4-20mA@.

Request the current pressure in the service menu:

"M" ≡ SERVICE ≡ Pressure

Only use sensors with a 4-20mA output signal.

It is possible to program the measuring range of the used pressure transmitter:

"M" ≡ BASIC PROGRAM ≡ Funct. IN 4-20mA ≡ max. pressure

PT100 Connection for temperature sensor PT100

Function	Connection	Test time	Action
Temperature compensation	PT100, integrated in sensor or external	none	Temperature compensation factor programmable 0.01 - 9.99%/°C
Temperature monitoring	PT100, integrated in sensor or external	programmable 1 - 99 seconds	S Continuous alarm S Entry in error list programmable S Switch off of the plant

Both functions can be used simultaneously.

Please connect a **temperature sensor PT100** to the input "PT100" if automatic temperature compensation (of the conductivity) is to be used; preferably use a conductivity sensor with integrated PT100. It is also possible to use a separate temperature sensor, but it has to be installed near the conductivity sensor.

"M" ≡ BASIC PROGRAM ≡ Temp. comp.

Water temperature monitoring

In addition to the temperature compensation, the unit can also monitor the water temperature. If a maximum value is exceeded the plant can be switched off and an alarm can be given.

"M" ≡ BASIC PROGRAM ≡ LV temperature

OUT Interface (Terminals 47 - 50)

Function	Connection	Test time	Action
Current interface 0/4 - 20 mA	Terminals 48 / 50 Load max. 500 Ohm	-	- Conductivity Permeate CD1
serial interface RS 485 not available at the moment!	Terminals 47 - 50 serial bus	-	-

It is possible to change the function of the output by exchanging the plug-in module and activating the corresponding function in the menu:

"M" ≡ BASIC PROGRAM ≡ Interface

Functioning

Switching on and power failure

After switching the unit on and after each power failure, the plant automatically returns to the Standby position. Prior to the Standby-position another flush takes place according to the programmed flushing duration (see programming). The plant can either be switched on manually by pressing the ARUN/STOP@ ("Production/Standby") or, e.g., automatically via existing level transmitters in the storage tank.

Production / Run

Use the ARUN/STOP@ ("Production/Standby") key to switch on the pressure pump(s) of the osmosis plant. The input valve opens and after a delay time the motor of the pressure pump starts. During production, it is possible to monitor the raw water pressure in front of the pressure pump (dry-running protection) as well as the pressure behind the pressure pump (overpressure protection) via pressure switches and to monitor the concentrate (concentrate flow) via a flow controller if the osmosis plant is equipped with the appropriate sensors. Additionally, the permeate conductivity is measured, displayed and compared with a minimum and maximum limit value.

The switching on and off can also take place automatically via level transmitters in the storage tank if the osmosis plant is equipped with a storage tank.

It is possible to interrupt the production temporarily via an external switch (input "STOP") in order to, e.g., regenerate a pre-connected softening plant.

Standby

Press the ARUN/STOP@ ("Production/Standby") key if water is no longer required. The pressure pump is switched off and the display shows "Standby". If the osmosis plant is equipped with a storage tank, the switching on and off can also take place automatically via level transmitters in the storage tank. In the case of plants with a flush valve, there is a re-rinsing phase (flush after production) prior to the position "Standby". During this time, AFlushA is shown on the display and the control lamp Aflush valveA (AFV@) lights up.

While switching from production to flush the pressure pump is, with opened input and flush valve, switched off for 5 seconds in order to achieve a pressure compensation of the plant.

The water pressure before and after the pressure pump, the concentrate flow as well as the conductivity limit values are not monitored in the AStandby@ position.

Flush after production

The osmosis plant can be equipped with a flush valve (connection "FV") in order to avoid unacceptable high deposits at the units. Flush is started after the end of the production if the storage tank is filled or by pressing the ARUN/STOP@ ("Production/Standby") key.

Program the necessary flushing duration in the basic program under "Flushing duration". Please set the flushing duration to 0 minutes if no flush is to take place after the production.

Flush is cancelled as soon as the ARUN/STOP@ ("Production/Standby") key is pressed or if water is requested via a limit transmitter in the storage tank.

Interval flush

After the last switch off (in the Standby position), flush can occur at fixed intervals. Unacceptable bacterial contamination of the units is avoided due to this interval flush. Enter the interval time (0 - 999 hours) and the flushing duration (1 - 99 minutes) in the basic program ("Interval flush").

Flush is cancelled as soon as the ARUN/STOP@ ("Production/Standby") key is pressed or if water is requested via a limit transmitter in the storage tank.

With production stop, no interval flush takes place. If an interval flush is not desired, the interval time (hours) has to be entered as @0@.

Quality flush and emergency service

During quality flush switch off at too high conductivity (LV Permeate Max: Switch off) should not be activated. During production, it is checked whether the permeate conductivity rises above the upper limit value (LV Permeate Max). If it is too high and **quality flush** (Quality flush: ON) has been programmed, quality flush is started for the programmed duration after the end of the set test time for the upper limit value.

It is switched back to production if the conductivity falls again due to the flush. However, if the conductivity remains as high, the **emergency service** starts after the quality flush. The emergency service is not shown extra on the display (display: @Production@).

Emergency service is terminated as soon as the conductivity is below the upper limit value.

Emergency program / By-pass

The function "Emerg. Program/BP" has to be selected for the input "PROG" in the menu "Funct. PROG". In addition to this, the contact type has to be selected. A float switch, which signals the emergency program, is connected to the input "PROGA. It is placed underneath the empty level.

A solenoid valve is, e.g., connected to the output "BP" in order to open the by-pass line.

If more water than the plant can supply is required during the production, the level in the storage tank falls to a level below the empty level. Emergency program starts as soon as the float switch for the emergency program responds, i.e. the relay for output "BP" switches. This leads, e.g., to the opening of a solenoid valve in order to supply water of a pre-connected softening plant. An additional pressure pump can also be switched on.

Emergency program ends when the empty level has been reached.

Conductivity monitoring

The integrated conductivity measuring instrument is used for the quality monitoring of the plant.

"OFL" appears on the display if the measuring range is exceeded.

Temperature compensation of the conductivity can either take place automatically or manually with a programmable compensation factor. Sensors with PT100 temperature sensors (or external sensors) have to be used for the automatic compensation. In the case of manual compensation (suitable with constant water temperature), enter the temperature. See ADescription of the inputs: PT100" for further explanations.

Description of the functionality and programming of the conductivity limit values:

LV Permeate Max: Maximum conductivity value which should guarantee a sufficient water quality.

"M" ≡ BASIC PROGRAM ≡ LV Permeate Max

LV Permeate Min: Minimum conductivity value which is necessary due to the existing raw water quality. But if conductivity does fall below this value, an error in the plant or the controller is present. (e.g. in the case of an interruption between controller and measuring sensor = parting of a cable).

"M" ≡ BASIC PROGRAM ≡ LV Permeate Min

The functionality of the limit values is stated in the table below:

Limit value	Test time	Action
LV Permeate Min fallen below	programmable 1 - 99 seconds	S Continuous alarm S Entry in the error list programmable S Switch off of the plant
LV Permeate Max exceeded	programmable 1 - 99 minutes	S LED display ACDmax@ lights up S Continuous alarm S Entry in the error list programmable S Switch off of the plant or quality flush

Programming

Start menu

Call the menu via the "M" key.

Menu selection

The current line position is displayed as a heading in CAPITAL LETTERS. Activate the selected/displayed menu option with the "ENTER" key, i.e. you "jump" into a submenu. Call the next menu point with the "DOWN" arrow key: thus you "scroll" the menu.

Input

Inputs are only possible in the program menu and in some SERVICE menu options.

Select a programming step with the "DOWN" and "UP" arrow keys and activate the input function via the "ENTER" key.

When entering digits, the digit/position to be changed flashes.

Change to the next or previous digit (now flashing) with the "Right" and "Left" arrow keys.

Change the value or selection with the "DOWN" and "UP" arrow keys.

Selected functions are marked with a T if selection is possible. In this manual they are marked with a * in the text.

Terminate the input function with "ENTER".

Change to the higher-order menu with the "M" key.

End menu

Return to the higher-order menu with the "M" key. After returning from the highest menu level, the unit is once again in the display function. The controller returns to the normal operating display (automatic menu end) after 2 minutes in the menu if a key is not pressed.

Information menu

"M" ≡ INFORMATION

Request the current settings without entering a password in the information menu.

The information menu is still displayed even if an incorrect password has been entered.

Programming

"M" ≡ BASIC PROGRAM

Enter password

The programming menu is protected by a 3-digit password (number between 000 and 999) in order to prevent unauthorised intervention in the programming.

Enter the password and confirm the input via the @ENTER@ key.

You are now in the menu PROGRAM.

Change password

Enter or change your individual password at any time. For this, enter the old password (OLD:) and then the new one (NEW:).

Flushing mode

It is possible to select and combine the units which are to be activated during flush as desired:

With pump 1 and/or with pump 2,
with output valve/permeate valve PV
and/or with input valve IV.

The flush valve FV is generally active for the duration of the flush.

"M"

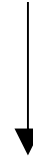

MENUE
Service
Information
Basic program

BASIC PROGRAM
Password Input
Password change
Password: 000

FLUSHING MODE
with Pump 1 -
with Pump 2
with valve IV
with valve PV

Flushing duration

Enter the desired duration for the re-rinsing (also see AFlush after production@):
The components selected under AFlushing mode@ as well as the flush valve FV are active during flush.

FLUSHING DURAT.	
Duration	10m

Interval flush

Enter the interval for the automatic flush during standstill of the plant in hours and the desired duration in minutes.

The components selected under AFlushing mode@ as well as the flush valve FV are active during interval flush.

INTERVAL FLUSH	
Interval	999h
Duration	99m

Quality flush

Depending on the permeate conductivity (quality), it is possible to start a flush during the Production if the limit value LV Permeate Max is exceeded. The function is switched on via @On@ and the maximum flush period can be entered.
For details see the section @Functioning@

QUALITY FLUSH	
On	
Durat. max	5m

Probe CD1 Permeate

Program the cell constant C of the used conductivity sensor:
(Possible values: 0.01 - 5.0/cm)

PROBE CD PERM.	
C =	01.00/cm

LV Permeate Max., Maximum limit value permeate conductivity

Max.:

Enter the maximum conductivity which should guarantee sufficient water quality.

Delay Max.

Delay time in minutes after which an alarm is triggered and/or the plant should be switched off if the maximum limit value has been exceeded.

Switch off

Program ASwitch offA if the plant should be switched off after the end of the delay time if the maximum limit value has been exceeded.

LV PERMEATE	
Max.:	100.0µS/cm
Delay Max	10m
Switch off	✓

LV Permeate Min., Minimum limit value permeate conductivity

Min.:

Minimum conductivity value which is necessary due to the existing raw water quality. But if conductivity does fall below this value, an error in the plant or the controller is present..

Delay Min.

Delay time in seconds after which an alarm is triggered and/or the plant should be switched off if the value has fallen below the minimum limit value.

Switch off

Program ASwitch offA if the plant should be switched off after the end of the delay time if the value has fallen below the minimum limit value.

LV PERMEATE	
Min.:	1.5µS/cm
Delay Min	20s
Switch off	✓

Temperature compensation

Automatic/manual

Please connect a **temperature sensor PT100** to the connection APT100" and program automatic compensation if the temperature compensation of the conductivity should occur automatically.

TEMP.-COMPENSAT.	
automatic	-
manual	✓
Factor	2.00
Temperat.	24°C

Factor (temperature coefficient in %/°C)

Enter the temperature compensation factor of the medium to be measured. The value for natural waters is approx. 2%/°C. Use reference measurements to determine the temperature coefficient for ultra pure water and with very small conductivities:

First, program the factor to 1.0 and measure the conductivity and the temperature of the medium at a temperature T1. Then measure the same medium at a temperature T2. Use the following formula to calculate the factor.

$$\text{Factor} = \frac{((\text{Conductivity (T1)} / \text{Conductivity (T2)}) - 1)}{(T1 - T2)}$$

Temperature

Please enter the existing water temperature for the manual compensation.

LV Temperature, Maximum limit value water temperature

Enter the maximum temperature for monitoring excess temperature:

LV TEMPERATURE	
	45°C
Delay	100s
Switch off	✓

Delay

Delay time in seconds after which an alarm is triggered and/or the plant should be switched off if the maximum temperature has been exceeded.

Switch off

Program ASwitch offA if the plant should be switched off after the end of the delay time if the maximum temperature has been exceeded.

Function Pump

Program the operating mode of the pressure pump/s of the osmosis plant:

Alternate: The pumps are installed in parallel and are operated alternately.

Serial: Pump 1 and pump 2 are connected in series. Output PU2 is switched with delay after PU1 has been switched on.

Select the output to which the pump is connected if the plant is operated with only one pump:

only pump 1: Output PU1 is switched

only pump 2: Output PU2 is switched

It is possible to enter the delay times for both pumps separately.

FCT. PUMP	
Alternate	-
Serial	-
only Pump 1	✓
only Pump 2	
Delay PU1	10s
Delay PU2	10s

Function Low water pressure, Input low water pressure monitoring LP

Program the desired effect of the connected contact for low pressure monitoring, normally closed or normally open.

Delay LP

Delay time in seconds after which an alarm is triggered and/or the plant should be switched off if the water/pressure is low.

FCT.LOW W.PRESS.	
norm. closed	-
norm. open	✓
Delay LP	5s
Restart	3x

Restart

Program how often the plant is to be switched on again after the switch off caused by low water pressure. The plant can be re-started up to 9 times until the final switch off.

Function Excess pressure, Input excess pressure monitoring HP

Program the desired effect of the connected contact for monitoring the pressure pump, normally closed or normally open.

Delay HP

Delay time in seconds after which an alarm is triggered and/or the plant should be switched off if the pressure is too high.

FCT.EXCESS PRESS
norm. closed -
norm. open
Delay HP 1s

Function Concentrate, Input concentrate flow monitoring CO

Program the desired effect of the connected contact for concentrate flow monitoring, normally closed or normally open.

Delay CO

Delay time in seconds after which an alarm is triggered and/or the plant should eventually be switched off.

Switch off

Program ASwitch offA if the plant should be switched off after the end of the delay time if the concentrate flow is too low.

FCT.CONCENTRATE
norm. closed -
norm. open ✓
Delay CO 5s
Switch off ✓

Function Motor protection, Input motor protection monitoring MP

Program the desired effect of the connected contact for monitoring the driving motor of the pressure pump/s, normally closed or normally open.

The delay time of 2 seconds after which an alarm is triggered and the pump/s is/are switched off is predetermined and cannot be changed.

FCT.MOTOR PROT.
norm. closed -
norm. open ✓

Function Stop, Stop input

Program the desired effect of the connected contact for the switch off of the plant, normally closed or normally open.

Delay Stop

Delay time in seconds after which the plant should be switched off.

FCT. STOP
norm. closed
norm. open ✓
Delay Stop 1s

Function PROG, programmable function input

Program the desired effect of the connected contact through which the following programmed function should be triggered, normally closed or normally open.

Emergency program/BP

The by-pass valve BP is opened. Due to this, the storage tank or a subsequent plant can be supplied with water in the case of possible external faults.

Tank overflow

The contact input is used for the tank overflow monitoring of the storage tank. If the storage tank is overflowing, the plant is switched off and an alarm ATank overflowA is triggered.

FCT. PROG.
norm. closed -
norm. open ✓
Em.Progam/BP -
Overflow ✓

Water meter

The controller has two independently operating water meter inputs.

Water meter 1 can, e.g., be used to record the raw water quantity. Water meter 2 can be used to record the permeate quantity.

Set the impulse numbers for the contact water meters or turbines in the menu:

WATER METER 1	
L/Imp.	1.000

Request the recorded quantities in the SERVICE menu, e.g.:

"M"≡ SERVICE ≡ WATER METER 1 ≡ Quantity: 9143 l

"M"≡ SERVICE ≡ WATER METER 2 ≡ Quantity: 4360 l

WATER METER 2	
L/Imp.	1.000

The memories of the water meters are also deleted in the SERVICE menu.

Metering

Use the output "Impulse" for the control of a dosing pump if metering is to take place during operation. Program the water meter to be used for metering, the volume for which an impulse is given as well as the impulse length. **Please note that it is not possible to enter an impulse interval in litres which is smaller than the basic number of the water meter.**

Alternatively, it is also possible to use the impulse output to duplicate the contact of the water meter signal. We recommend this if you, e.g., wish to control a hardness measuring instrument (e.g. Testomat 2000) quantity-dependently. For this, please observe the instructions of the connected hardness measurement instrument.

METERING	
active WM1	✓
active WM2	-
L/Imp.	
I.length	0.5s

Funct. IN 0/4-20mA input

Program the measuring range of the sensor if the osmosis plant is equipped with a pressure measuring transducer for the measurement of the pump pressure:

FCT. IN 4-20MA	
Max.press.	25bar

Request the current pressure in the SERVICE menu, e.g.:

"M"≡ SERVICE ≡ Pressure 14.3bar

Function OUT PR output

Program the function of this volt-free relay output **PR**:

CDmax: Relay switches if the conductivity ACDmax.@ has been exceeded

or

Tank empty: Relay switches if the storage tank is empty

or

Production: Relay switches if the plant is in operation

or

Stop/Standby: Relay switches if the plant is in standby or has been stopped.

FCT. OUT PR	
CD Max	✓
Tank empty	-
Production	-
Stop/Standby	-

Interface

Program the type of the built-in serial interface according to the used plug-in card. The RS232 is a standard interface for firmware updates via PC or for connecting a protocol printer.

The interface card RS232/RTC/0-20mA is equipped with a current transformer which can be used for the output of the conductivity. Program the desired/necessary output signal.

INTERFACE	
RS232	✓
RS485	-
0-20mA	✓
4-20mA	-

Baud rate

Select the speed rate of the serial interface.

BAUD RATE	
9600	-
19200	✓

Release

With the built-in serial interface, it is possible to either program the controller or to request controller data via a PC/laptop and to carry out remote maintenance via an analogue, digital or wireless modem (the @Softmaster ROE 2@ program is necessary):

Release mode:	none	=	Data transfer locked
	read-only	=	Only reading of data is allowed
	active	=	Reading/writing of data and programming allowed

RELEASE	
none	✓
read only	-
active	-

Language

Selection of the desired display language:

At present, these five Astandard@ languages are available. Other languages are available if desired by customers.

LANGUAGE	
German	-
English	✓
French	-
Italian	-
Dutch	-
Polish	-

Serial number

With this function it is possible to display the serial number of the unit.

SERIAL-NO.
123456

ASERVICE@ menu

Request and change current settings and statuses of the unit in the service menu.

Manual flush

Start a flush of the plant via this manual function. After the start a return to the operating display occurs. The maximum flushing duration is limited to 99 minutes. End the flush with the ARun/Stop@ key.

Flush	99m
-------	-----

Automatic flush

Start a flush of the plant with the programmed flushing duration (also see "M" ≡ BASIC PROGRAM ≡ Flushing duration) via this manual function. After the start a return to the production display occurs.

It is possible to end the flush at any time with the ARun/Stop@ key.

Flush	1m
-------	----

Error history

Open the error history via Adisplay@. The error history is a list of the errors which have occurred during current operation.

An occurred error is recorded with error number, time and date,

e.g.: Low w. press. 6
 16:56 16.09.03

A maximum of 20 errors are stored in a circular buffer, i.e. the oldest error is overwritten by the next error if the buffer is full.

The buffer of the error history is deleted via Adelete@ and recording restarted.

The list is not deleted after a power failure.

ERROR HISTORY	
display	
clear	

Calibration of the conductivity sensor CD

**Calibration should only take place with calibration solvents in accordance with DIN EN 27888 !
Inappropriate calibration leads to undefined display values !**

Dry and zero point calibration

With the **calibration method CAL. CD ZERO**, it is possible to compensate measuring errors (offset) which occur due to very long supply lines to the measuring sensor.

The sensor is calibrated AdryA, i.e. it is not dipped into the measuring medium:

- a) Either with a built-in sensor, before the tube system is filled
or
- b) with a not yet built-in sensor, but already equipped with the correct cable length.

Call the following menu option to start calibration

"M" ≡ SERVICE ≡ Cal. CD Zero and start by pressing AENTER@.

The unit now corrects the measuring error caused by the cable length via subtraction. The process ends automatically.

Desired value calibration

With the **calibration method CAL. CD desired value**, it is possible to correct measuring errors caused by a soiled sensor.

It is recommended to also calibrate with this method if there are high accuracy demands in a small measuring range. This calibration method also enables measurements with a sensor whose cell constant is not exactly known.

Procedure:

Carry out the calibration with an appropriate KCl standard calibration solvent. For this, dip the measuring sensor into the calibration solvent. Please observe that the sensors are free moving in the vessel.

- **With automatic temperature compensation:** First, enter a temperature coefficient of 1.90%/°C in the BASIC PROGRAM menu ATemp.-comp.@ and the value of the standard calibration solvent at 25°C under desired value. After dipping the sensor into the calibration solvent, wait approx. 2 minutes before starting the calibration until the sensor has the same temperature as the solvent.
- **With manual temperature compensation:** If you wish to calibrate a sensor without a temperature transmitter, you have to enter "**manual temp.-compensation**" in the basic program and the temperature of the calibration solvent under "**Temperature**". The temperature of 25°C for the calibration solvent is also valid here.

1. Call the menu ACalibrate CD@

"M" ≡ SERVICE ≡ Cal. CD Desired value

2. Enter the desired value of the conductivity and save the value by pressing AENTER@.

3. Call the following menu option to start the calibration

"M" ≡ SERVICE ≡ Cal. CD Start and start by pressing AENTER@.

The unit now corrects the measuring error by forming a correction factor. Calibration is ended automatically.

Note!

Inappropriate calibration can lead to the display of undefined values. Incorrect calibrations can only be corrected via a new calibration or via a ACAL. CD RESET@.

Note on calibrating:

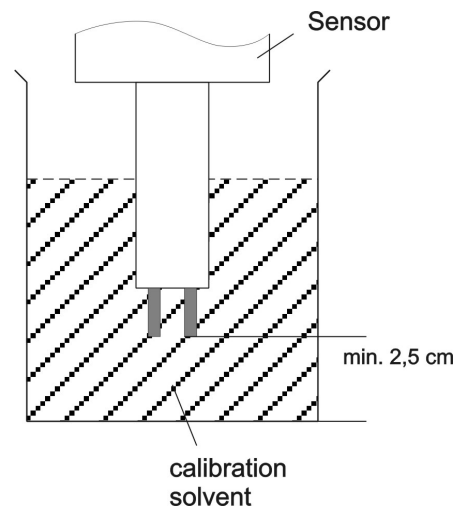

Operating hours

The unit records the operating hours of the pressure pump(s) and thus the load of the units. Request the current operating time in the service menu:

"M" ≡ SERVICE ≡ Operating hours

Reset the operating hour meter:

After exchanging the pump(s) or the module, it is possible to reset the current operating time to 0 hours:

"M" ≡ SERVICE ≡ Operating hours ≡ Reset

Water meter

Both water meters are equivalent and can be used freely.

Water meter 1

Water meter 1 records, e.g., the supplied raw water quantity in litres for quantity-dependent metering.

Reset (ENTER): Leads to a reset of the currently saved total quantity.

Water meter 2

Water meter 2 records, e.g., the permeate quantity in litres counted since the last reset.

Reset (ENTER): Leads to a reset of the currently saved total quantity.

Pressure

Request the current pressure in the service menu:

Measuring input **IN 4-20mA** for the connection of a pressure transmitter with a 4-20mA output is used for the pressure monitoring of the pump or the unit. Please program the measuring range of the used pressure transmitter in the BASIC PROGRAM menu:

PRESSURE
5.6bar

"M" ≡ BASIC PROGRAM ≡ Funct. IN 4-20mA ≡ max. Pressure

Time/Date

Please observe that in the case of units without a clock module the time only runs if the unit is switched on. Correct, if necessary, the time and date after a longer period of power failure or if the plant has been switched off.

TIME	DATE
10:23	21.07.03
automatic	-

Display: "M" ≡ SERVICE ≡ Time Date

The display shows the date and time of the controller.

Set: Press the "ENTER" key under menu "M" ≡ SERVICE ≡ Time Date.

Set the time and date by selecting the desired function with the arrow keys and trigger it by pressing AENTER@. Press the "ENTER" key again to save the setting and to return to the display function.

Set a check mark for the automatic change-over from summertime to wintertime.

Diagnosis

The diagnosis menu displays the current statuses of the in- and outputs. For checking purposes (e.g. during commissioning), the output statuses can be manually manipulated with the @DOWN@ and AUP@ keys. Please make sure that downstream plant parts cannot be damaged.

Active statuses (switched relay, switched input) are represented with Aon@, inactive statuses with Aoff@, e.g.:

OUTPUT IV or INPUT MP
 off on

The analogue input displays the existing value, e.g.:

INPUT MA
 16.8mA

Software status

Request the current software status here:

SOFTWARE
91Mxxx DD.MM.YY

Menu structure

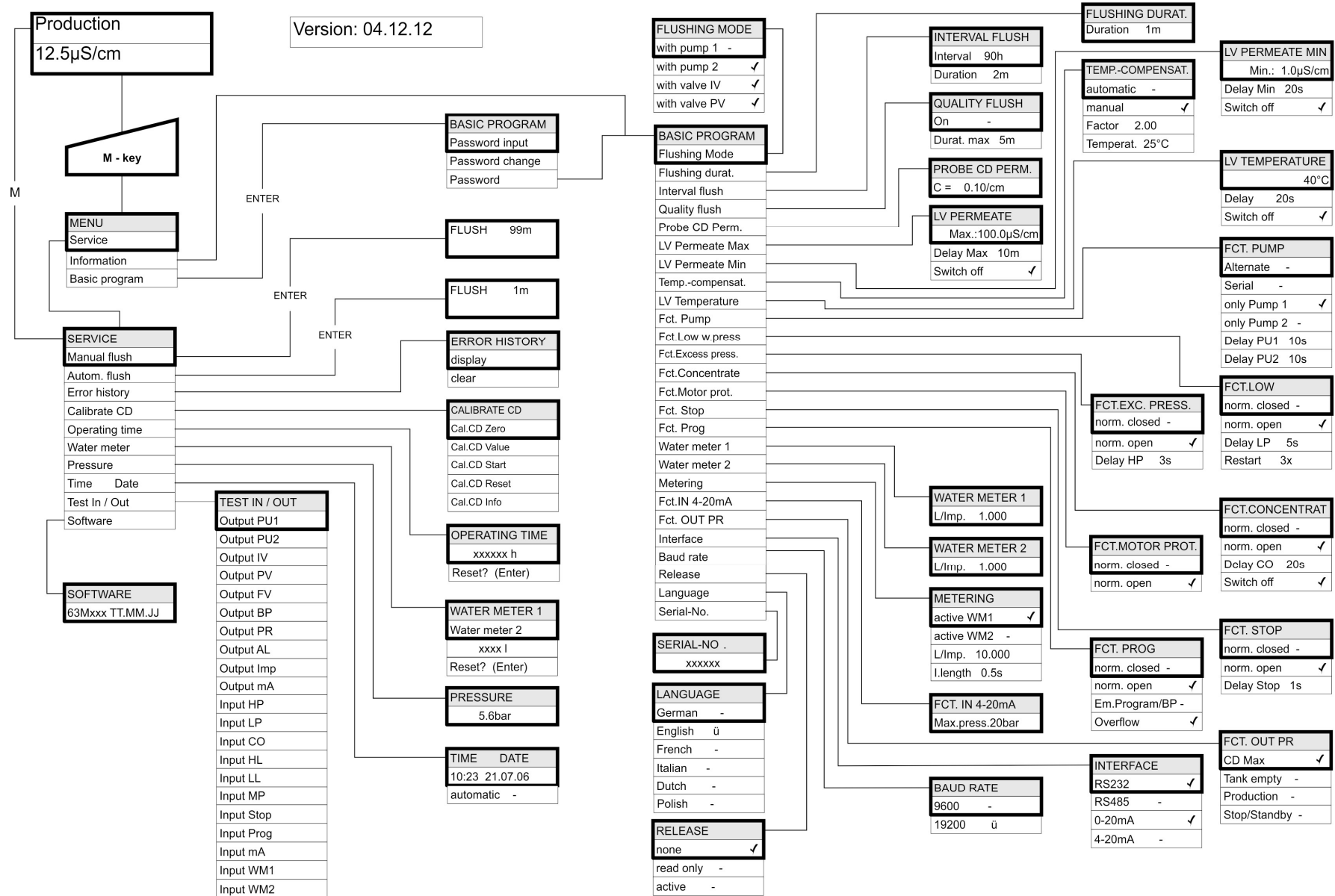

In order to call the factory>s basic setting, switch the unit on while pressing the ADOWN@ key. Your individual programming will be lost!

Technical appendix

Example for an osmosis plant layout

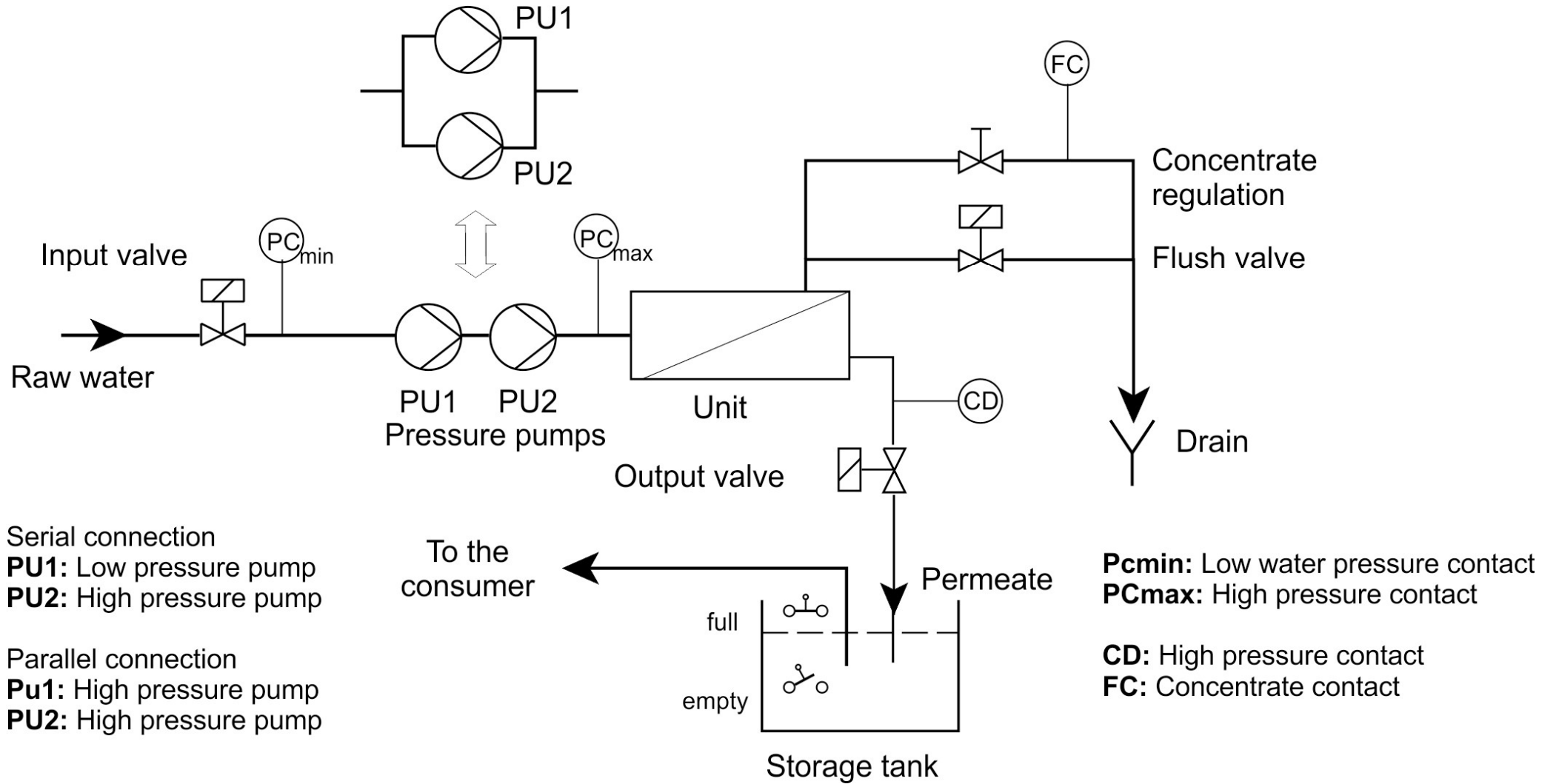

Connection example

(displayed relay position: Device deenergized)

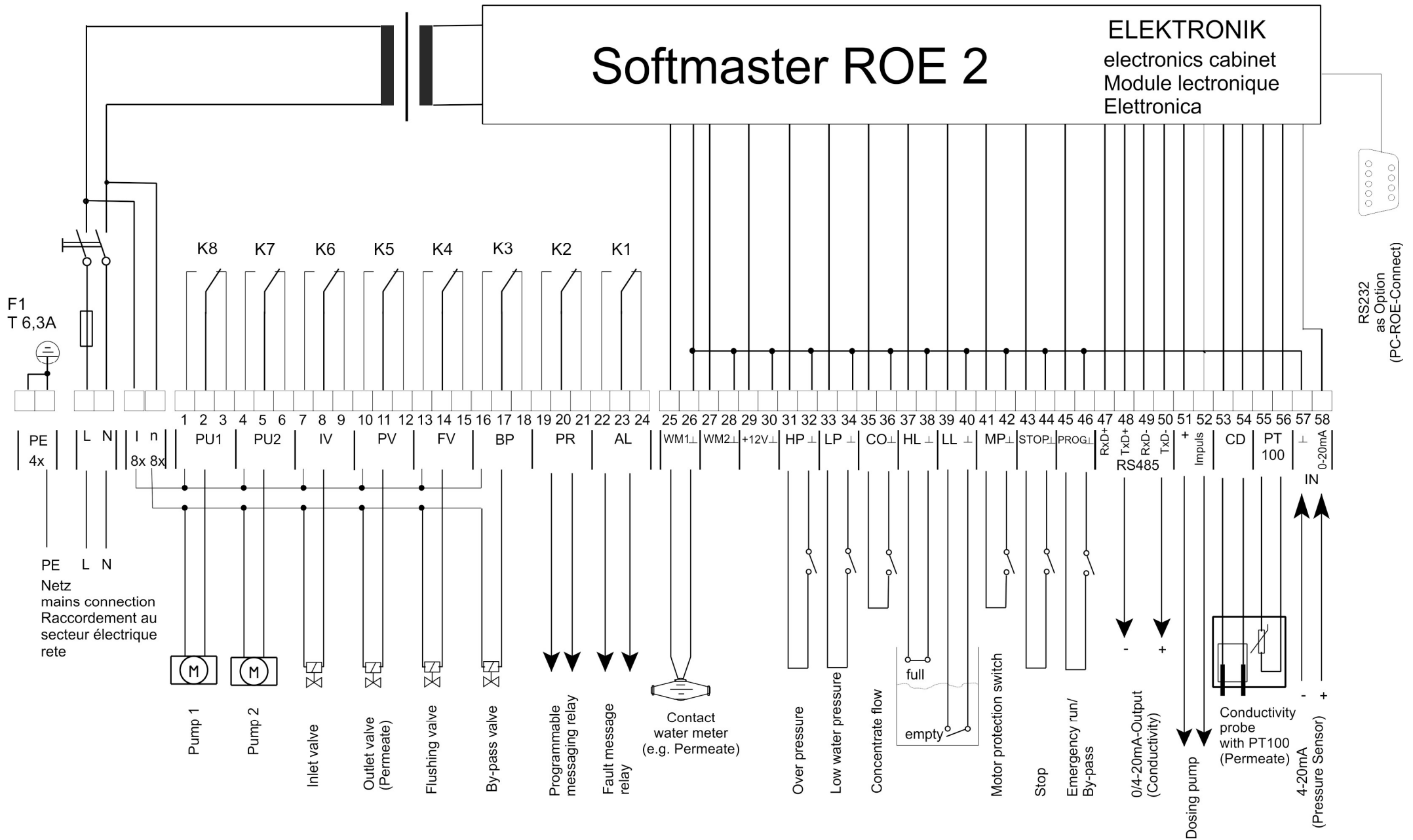

Connection example for 24 V

(displayed relay position: Device deenergized)

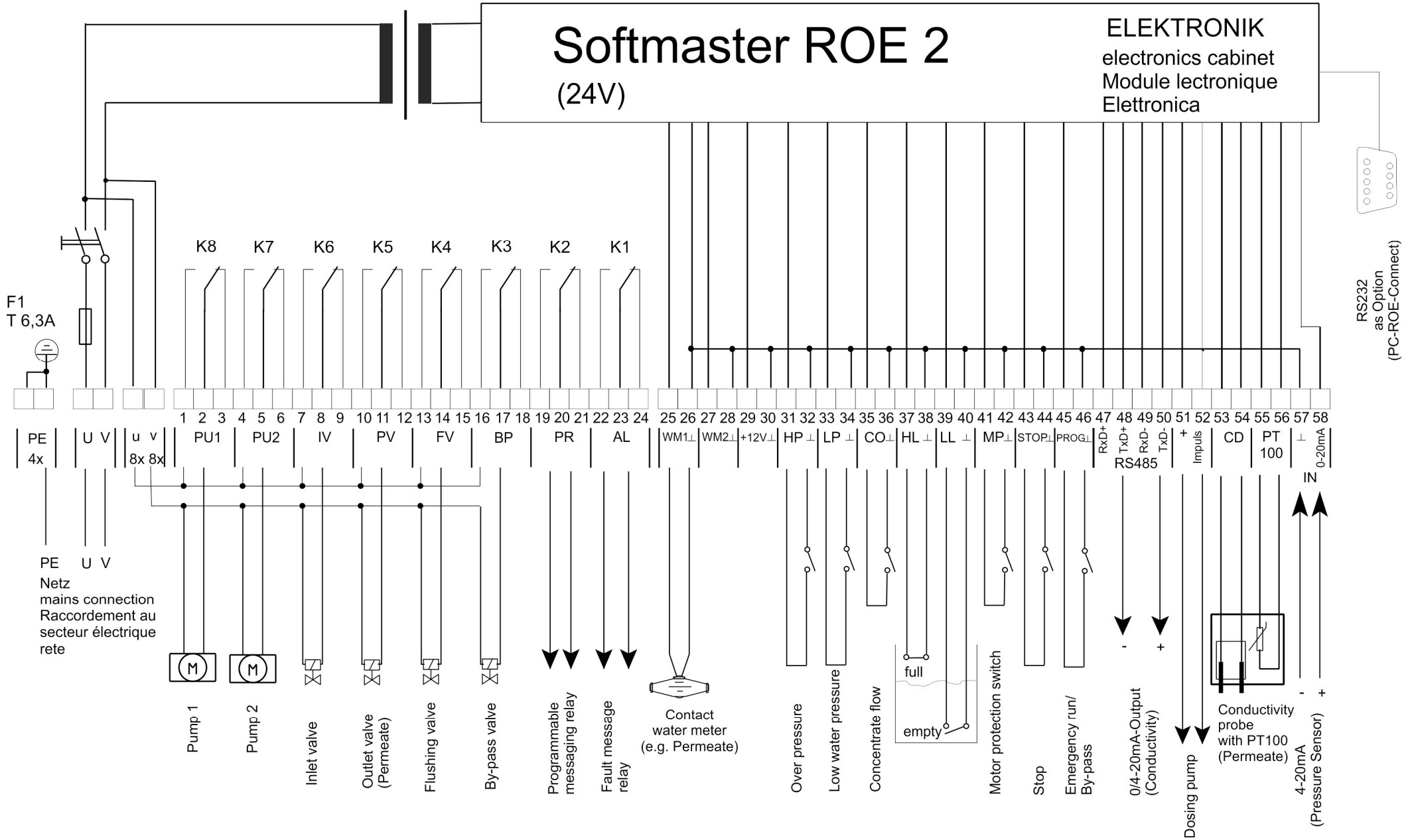

Conformity Declaration



EC Conformity Declaration



for the following product

**Softmaster ROE 2
Microprocessor controllers for reverse osmosis plants**

We hereby confirm that the above product conforms to the principal health and safety regulations laid down in the EC Directives 2014/30/EU and 2014/35/EU.

This declaration applies to all units produced in accordance with the attached manufacturing documents which are a constituent part of this declaration.

The product was assessed with reference to the following standards:



EN 61000-6-4: Electromagnetic compatibility, Generic emission standard

EN 61000-6-2: Electromagnetic compatibility, Generic immunity standard

EN 61010-1: Safety requirements for electrical equipment for measurement, control and laboratory use



BS EN 61000-6-4+A1: Electromagnetic compatibility, Generic emission standard

BS EN 61000-6-2: Electromagnetic compatibility, Generic immunity standard

BS EN 61010-1+A1: Safety requirements for electrical equipment for measurement, control and laboratory use

This declaration is made on behalf of

**GEBRÜDER HEYL
Analysentechnik GmbH & Co. KG
Orleansstraße 75b
31135 Hildesheim**

by

Jörg Tilman Heyl

General Manager

Hildesheim, 16/09/2021

Technical Data

Power supply: 230 - 240 V or 24 V or 115V+/-10% / 50 -60 Hz,
Safety fuse T6.3A

Power consumption without external load: max. 9 VA

Degree of protection: IP65

Protection class: I

Conformity: EN 61000-6-2, EN 61000-6-4, EN 61010-1
BS EN 61000-6-4+A1, BS EN 61000-6-2,
BS EN 61010-1+A1



Ambient temperature: 0 - 45°C

Measuring ranges:

Measuring range	Cell constant	Sensor name, e.g.
0,1 – 99,9 $\mu\text{S/cm}$	0.01 cm^{-1}	SOE0, STE0 PT100
1 – 999,9 $\mu\text{S/cm}$	0.1 cm^{-1}	SO1, ST1 PT100, SOE1
5 – 4999 $\mu\text{S/cm}$	0.5 cm^{-1}	SO5, SOE5, ST5 PT100
10 – 9999 $\mu\text{S/cm}$	1.0 cm^{-1}	SD10, SO10
50 – 49999 $\mu\text{S/cm}$	5.0 cm^{-1}	STE50 PT100

Accessories for calibration:
Conductivity solvent 1413 $\mu\text{S/cm}$ 230 ml Art. No.: 425404

Housing dimensions surface/panel-mounted ROE 2:
W x H x D = approx. 270 x 295 x 130 mm
Housing made of ABS,
Panel cut-out 262mm x 146mm, +1mm,
Mounting depth approx. 90mm,
Front frame dimensions 270mm x 155mm

Weight: approx. 2.6 kg

We reserve the right to make technical changes without notice in the interest of constantly improving our products!

.....

SOFTMASTER_ROE2_GB_151014.DOCX



Gebrüder Heyl
Analysentechnik GmbH & Co. KG
Orleansstraße 75b
D 31135 Hildesheim
www.heylandanalysis.de



Scan the code and
visit us on our website!